



**National Energy Corporation of Trinidad and Tobago Limited**

# **Agenda**

- Safety Brief
- **Welcome Remarks-** Dr. Vernon Paltoo-Manager, Energy Industry Development
- **Remarks-** Melissa Marchong
- **Presentation –** Daren Ragoonanan
- Questions & Answers



**National Energy Corporation  
of Trinidad and Tobago Limited**

**PROFILES FOR DERIVATIVE MELAMINE  
MANUFACTURING BUSINESS OPPORTUNITIES**

Presentation to AMCHAM

October 2011

# Outline of Profile Document

- Overview
- Melamine in Manufacturing
- Major Markets for Melamine Derived Products
- Concepts for Melamine Manufacturing Industries  
Development in Trinidad and Tobago
- Profile 1 – Moulding Compounds
- Profile 2 - Dinnerware
- Profile 3 – Adhesives
- Profile 4 – Coatings
- Profile 5 – Laminates
- Profile 6 - Plasticizers
- The Way Forward

# Overview

- In May 2010, Methanol Holdings Trinidad Limited (MHTL) began producing melamine from its 60,000 tpy production facility, which forms part of its AUM I Complex.
- The production of this commodity, downstream of ammonia, provides an opportunity to leverage the strengths of the energy sector in order to develop linkages with the manufacturing sector.
- The Government of the Republic of Trinidad and Tobago (GORTT), subsequent to the Melamine Symposium held on November 17<sup>th</sup> 2010, initiated the development of melamine manufacturing profiles.
- These profiles can be used as a tool by manufacturers and potential investors in developing business opportunities and further adding value to the country's natural gas resource.

# **MELAMINE IN MANUFACTURING**

# Melamine End Markets

End Market	Application	Quality/Characteristic
<b>Automotive</b>	<ul style="list-style-type: none"> <li>• Coating for vehicle body paints</li> <li>• Flame-resistant foam</li> <li>• Interior panels and dash</li> </ul>	<ul style="list-style-type: none"> <li>• Coating, color retention, wear resistance, scratch resistance</li> <li>• Low weight</li> <li>• Low-temperature flexibility</li> <li>• High sound absorption capacity</li> <li>• Good thermal insulation properties</li> <li>• Constant physical properties over a wide temperature range</li> <li>• Application temperature up to 240° [465°F]</li> <li>• Flame resistance</li> <li>• Abrasiveness</li> </ul>
<b>Agriculture</b>	<ul style="list-style-type: none"> <li>• Rubber vulcanizing agents</li> </ul>	
<b>Building &amp; Construction</b>	<ul style="list-style-type: none"> <li>• Adhesive resins for ceiling tiles</li> <li>• Beams</li> <li>• Carbonitriding of steel</li> <li>• Oriented Strand Board (OSB)</li> <li>• Concrete plasticizers</li> <li>• Concrete shuttering</li> <li>• Construction panels Gypsum</li> <li>• Medium Density Fiberboard (MDF)</li> <li>• Parallel strand Lumber</li> <li>• Particle board</li> <li>• Plywood</li> <li>• Structural foams</li> <li>• Laminated Veneer Lumber (LVL)</li> <li>• Iron on Veneer</li> </ul>	<ul style="list-style-type: none"> <li>• Strength, moisture-resistance, efficient utilization of wood, flow characteristics (concrete), thermal isolation, sound absorption</li> </ul>

# Melamine End Markets

End Market	Application
<b>Electrical &amp; Electronics</b>	<ul style="list-style-type: none"><li>• Wind power blades</li><li>• Computer cases</li><li>• Switch plates</li><li>• Junction boxes</li><li>• Raceways</li><li>• Domestic appliances</li><li>• Printed circuit boards</li><li>• Television sets</li><li>• Switch plates</li></ul>
<b>Fibers, Textiles &amp; Coatings</b>	<ul style="list-style-type: none"><li>• Banknotes</li><li>• Drink cans</li><li>• Fluorescent paints</li><li>• Intumescent paints</li><li>• Leather tanning agents</li><li>• Maps</li><li>• Matting agents</li><li>• Printed textiles</li><li>• Symphase Technology</li><li>• Special glossy papers</li><li>• Wallpaper</li><li>• Wrinkle-free clothing</li></ul>
<b>Furniture</b>	<ul style="list-style-type: none"><li>• Bathroom fitments</li><li>• Bedroom furniture and fitments</li><li>• Cabinets desks</li><li>• Furniture tops</li><li>• Kitchen and bathroom counter-tops</li><li>• Nursery and children's furniture</li></ul>

# Melamine End Markets

---

## End Market

## Application

### Other

- Anti-punking agents in binders for glass fibre insulation
- Ion-exchange resins
- Nitrification agent (nitrogen force)
- Printing ink
- Raw material for cyanuric acid (swimming pools disinfectant)
- Starting material for melamine derivatives and salts for a variety of applications

# Other Input Materials Required for Selected Products

Product	Other Material
Moulding Compounds	Formaldehyde, Alpha-Cellulose (Refined cellulose)
Tableware, Dinnerware and Utensils	Moulding Compound
Toys	Moulding Compound
Formica	Formaldehyde
Laminates (with culture oriented patens)	Urea Formaldehyde
Adhesives	Urea Formaldehyde
Melamine faced chipboards for office and home furniture	Urea Formaldehyde & Adhesives
Melamine phosphates – Flame Retardants	Phosphoric acid
Hi Tech vacuum package coating – Symphase Technology	Proprietary
Concrete Plasticizers	Sulphur compounds
Concrete Shuttering	Urea Formaldehyde
Iron-on Veneer Sheets	Urea Formaldehyde
Toilet Compartments (Floor to Ceiling Supported)	Wood, Laminates & Adhesives
Office Compartments	Wood, Laminates & Adhesives
Furniture, Kitchen and Bathroom Countertops	Wood, Laminates & Adhesives
Toilet Seats	Moulding Compounds
Electrical Switch Plates, Junction Boxes and Raceways	Moulding Compounds

# Other Issues for Consideration

- Firm buyers should be secured for a significant portion of the products before starting a business venture.
- There may be a need to acquire proprietary technology and standardized work processes for some of these business opportunities.
- It would be useful to obtain ISO 9000 certification as it relates to quality and management systems.
- Melamine has been used in consumer applications without incidents since it was commercialized over 40 years ago. Even direct or indirect oral contact with any of these products is completely safe.
- No personal injuries are likely in the event of spillage. Melamine has a very low acute toxicity. If it is inhaled or gets in the eyes, it is only mildly irritating, and the irritation quickly subsides when exposure ceases.
- Melamine is absolutely not intended to be used as an ingredient in food and feed applications and therefore should never be used as such. Melamine in bonded form is widely and regularly used in dinnerware, meeting the most stringent requirements of the US Food and Drug Administration (FDA).

# Major Market Applications of Melamine

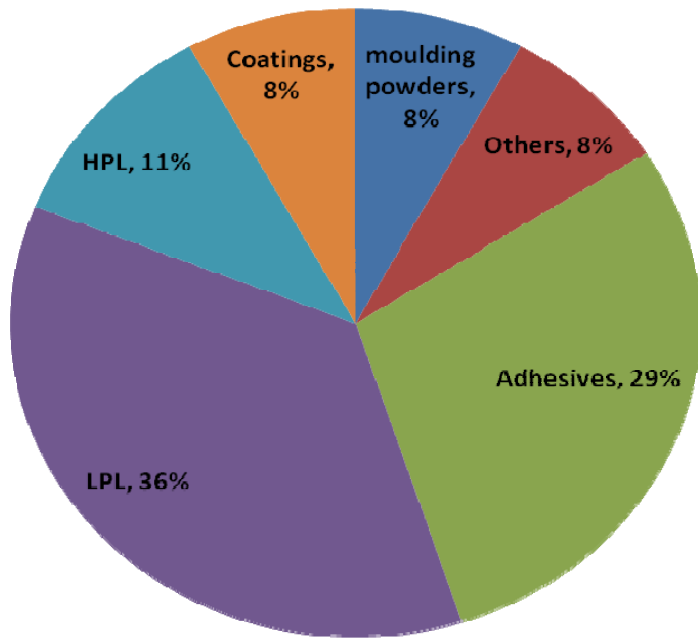

World Market Segments

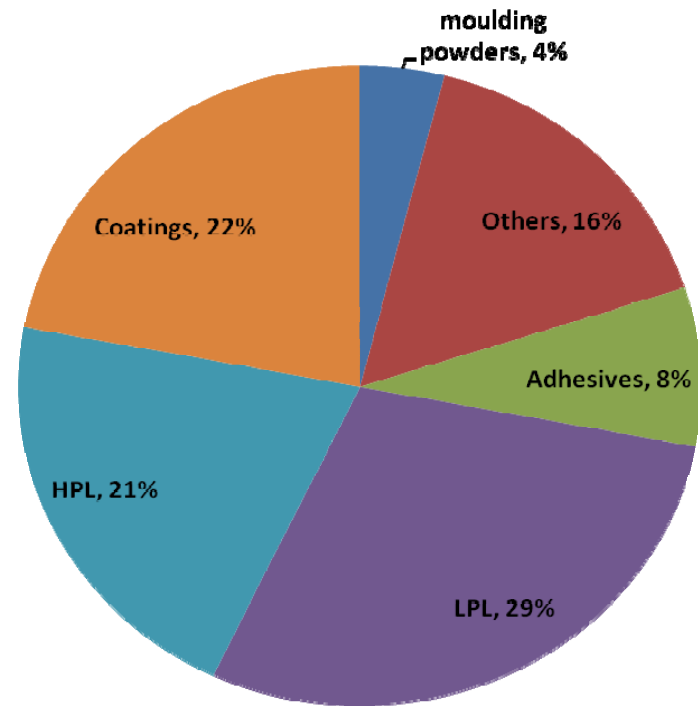

Americas

# Melamine Market Outlook

- Consumption of melamine in 2010 was estimated to be 1.264 million metric tonnes increasing slightly from 2007 when consumption was at 1.225 million metric tonnes.
- Worldwide capacity has increased by 400,000 metric tonnes or 9% from 2007 to 2010 while consumption only increased by 1%.
- This has resulted in a decrease in the utilization of melamine facilities from 87% in 2007 to 70% in 2010.
- Even so, it is projected that the market size for melamine in 2015 would be 1.663 million metric tonnes globally.
- South and Central America will see growth of 4.8% with increased demand for melamine use in wood adhesives and laminates.
- Over the past twelve to eighteen months, there has been a steady increase in the price of melamine, from US\$1,862 per tonne in January 2010 to US\$2,435 per tonne in February 2011 on the US bulk domestic market.

# Melamine Derivatives Business Opportunities Profiles

- Melamine Moulding Compounds
- Dinnerware
- Adhesives
- Coatings
- Laminates
- Plasticizers



## Manufacturing Industries from Melamine

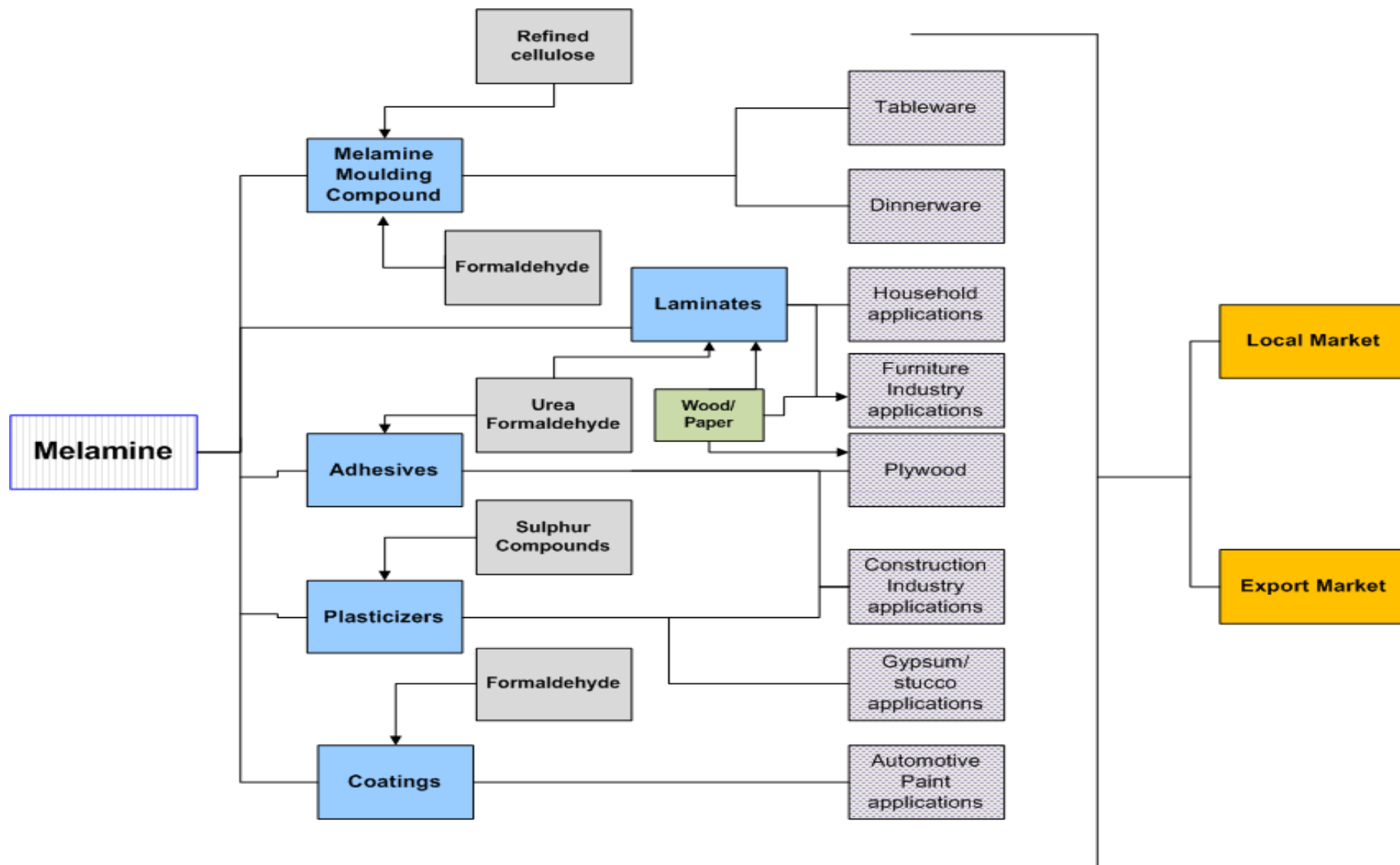

# Conceptual Estate Plan for Downstream Melamine Industries

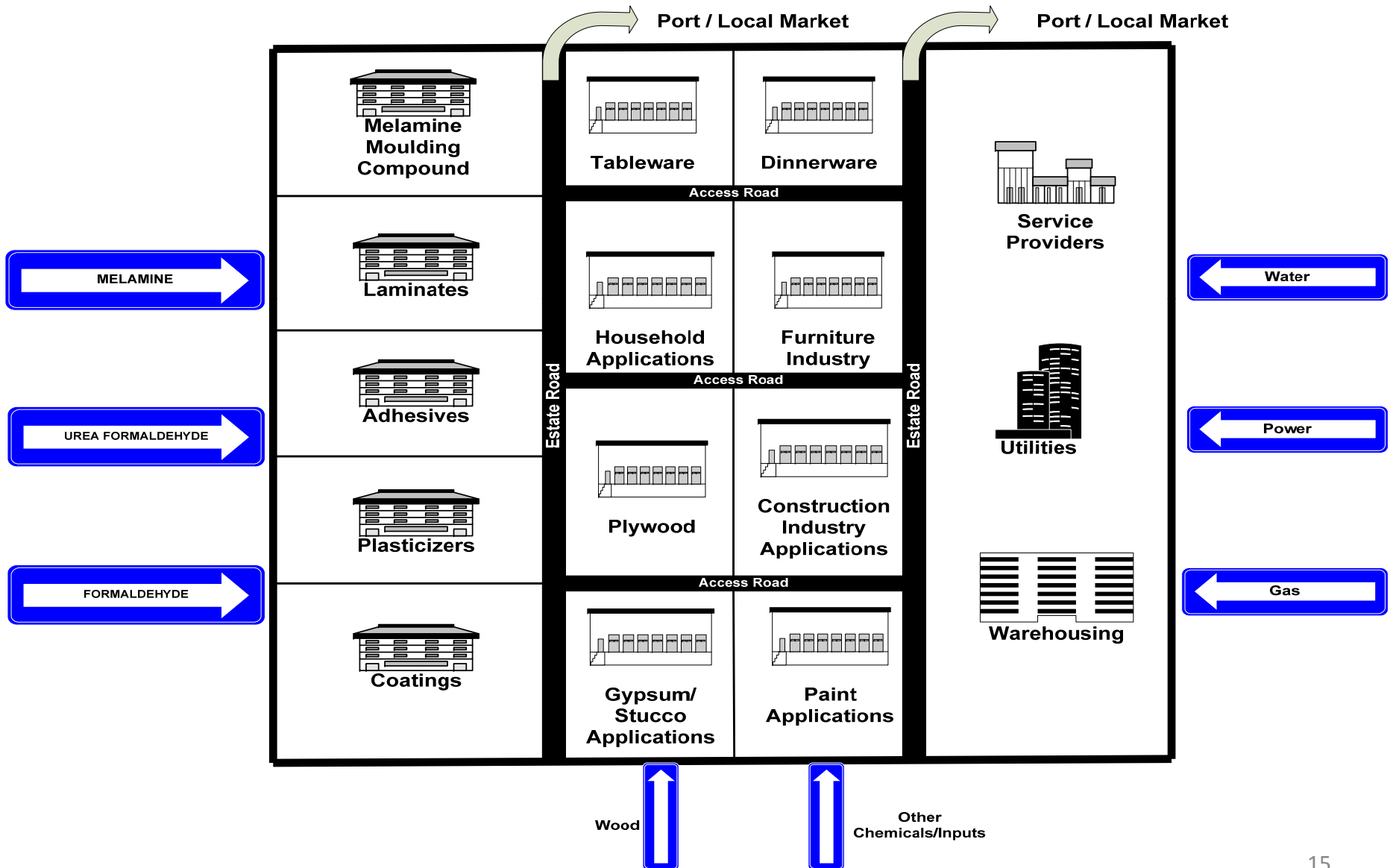

# **BUSINESS PROFILES FOR MELAMINE DERIVATIVES**

# Melamine Moulding Compounds



# Melamine Moulding Compounds

## Pre-requisite for Melamine Moulding

Melamine Moulding Compound is manufactured by combining an alpha-cellulose (~30%) with melamine and formaldehyde (70%), which is available in an unlimited range of colours.

It produces mouldings with surface hardness unsurpassed by any other plastics.

Moulded parts have excellent resistance to abrasion, boiling water, detergents, weak acids and weak alkalis as well as acidic foods and extracts. Compared to thermoplastics, melamine moulding compounds exhibit:

- Superior surface hardness that cannot be duplicated by thermoplastic materials
- Superior heat resistance
- Environmentally friendly raw material components that do not contain halogens, chemicals or organic solvents
- Superior chemical resistance
- Excellent scratch resistance that cannot be duplicated by engineered thermoplastic materials
- Unparalleled UV stability and color retention

Melamine Moulding Compound is particularly well-suited for moulding food contact products, including quality dinnerware for domestic and commercial food service.

Melamine Moulding Compound molded articles are specifically approved for food contact.

# Market Data

- With new demand for automobile parts, at present the overall global production of Melamine Moulding Compound appears to be under supplied.
- Overall outlook for global market demand is good with increasing demand in South and Central America, as well as the African markets.
- Due to the present economic downturn, forecast for projected growth for the next 10 years is about 3% per annum.
- The future market will be driven by creative internet or e-marketing, innovations in the industry and economics. The current retail price for Melamine Moulding Compound range from US\$2.00 to 3.00 per lb for coloured product and US\$1.25 to 1.75 per lb for non-coloured.
- The historical demand for the product had an average growth rate of about 3% over the last ten years.
- Specific markets for production from Trinidad and Tobago are Regional, South and Central America, Africa and the US.
- There are no major potential barriers to accessing these markets.
- Some of the major manufacturers of melamine moulding compound include:
  - Amity Thermosets PVT Ltd (India)
  - [Kaihua County Hao Teng Melamine Products Factory](#) (China)
  - [Shijiazhuang Golden Color Chemical Co., Ltd.](#) (China)
  - [Henan Premtec Enterprise Corporation](#) (China)
  - [Jiashan Luyuan Chemical Co., Ltd.](#) (China)
- Major sources for supplying turnkey operations and equipment are from China, Taiwan, US and India.

# Melamine Moulding Compounds

Item	Estimated Requirement*
Floor Space	1000 sq m
CapEx	US\$250,000 – 500,000
Working Capital	US\$50,000 – 100,000
Capacity range	3 – 5 tonnes per day
Manpower requirement	30 - 40
Utility Requirements	500 kW electricity 20 tpd water
Potential Markets	T&T, SA, CA, Africa, US, Europe
Other Input Materials	Refined cellulose, formaldehyde

\* depending on plant size and level of automation

# Melamine Moulding Compounds

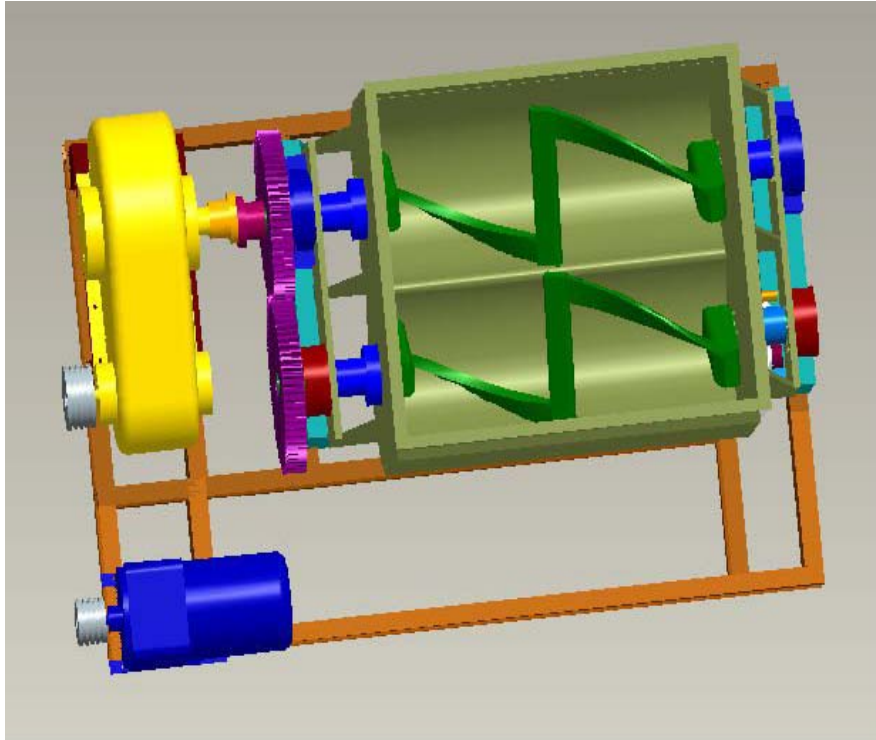

The major pieces of equipment used for processing melamine formaldehyde molding compound (MF powder) include:

- Chemical Reactor Vessel
- Kneading Machines (kneading mixers)
- Belt Dryers
- Crushers
- Ball Mills,
- Dust Separators
- Dust Collectors
- Powder Sieve

## ***Melamine Moulding Compound Mixing Equipment***

Vat volume: 1500litres, 2000litres, 2500litres  
Rotations: 30 - 50 per minute  
Power: 18.5kW, 26kW

# Dinnerware



# Dinnerware

- The current trend for eating outdoors has led to melamine enjoying a ready-market and it is now widely available, although nowadays, it tends to be used for casual outdoor dining rather than formal dinner parties.
- Adding decorative overlays during the moulding cycle can enhance the appearance of the moulded articles.
- This important added value will allow us (T&T) to insert our unique local brand art-form skewed to worldwide end users' cultural and other preferences.
- This novel artistic medium with expressions that are beautiful or thought-provoking, akin to our Carnival ingenuity, this time made in T&T appears to be perfectly suitable for international e-buying. The added advantage is that this will also serve to promote our natural, cultural and industrial assets.

# Market Data

- Overall global production of uniquely designed high-end Melamine Dinnerware at present appears to be in good demand.
- Overall global market demand is favourable with increasing demand from Regional, South and Central America and Africa markets. This global market requirement is currently about 6 million units per year.
- Forecast projected growth for the next 10 years is approximately 3% per annum.
- The future market will be driven by creative internet or e-marketing, innovations in the industry and economics.
- The current retail price for a melamine dinner plate ranges from US\$0.80 to US\$2.85.
- The historical demand for the product had an average growth rate of about 4% over the last ten years.
- Specific markets are Regional, South and Central America, Africa and the US.
- No major potential barriers to accessing these markets are foreseen.
- There are several hundred current manufacturers and suppliers of melamine dinnerware worldwide. Major manufacturers include:
  - [Henan Hylink Imp. & Exp. Co., Ltd.](#) (China)
  - [Quanzhou Jieli Trade Company Limited](#) (China)
  - [Liyang Xinrong Melamine Products Co., Ltd.](#) (China)
  - [Fuzhou Fortune Homeware Co., Ltd.](#) (China)
  - [Zhejiang Lesheros Houseware Manufacturing Co., Ltd.](#) (China)
- Major sources for supplying turnkey operations and equipment are from China, Taiwan, US and India.

# Dinnerware

Item	Estimated Requirement *
Floor Space	600 sq m
CapEx	US\$300,000 – 500,000
Working Capital	US\$60,000 – 100,000
Capacity range	600 to 1,200 pieces per day
Manpower requirement	15 – 40
Utility Requirements	60 kW electricity 5 tpd water
Potential Markets	T&T, SA, CA, Africa, US
Other Input Materials	Melamine moulding compounds

\* depending on plant size and level of automation

# Flow Diagram for Melamine Tableware Making Plant

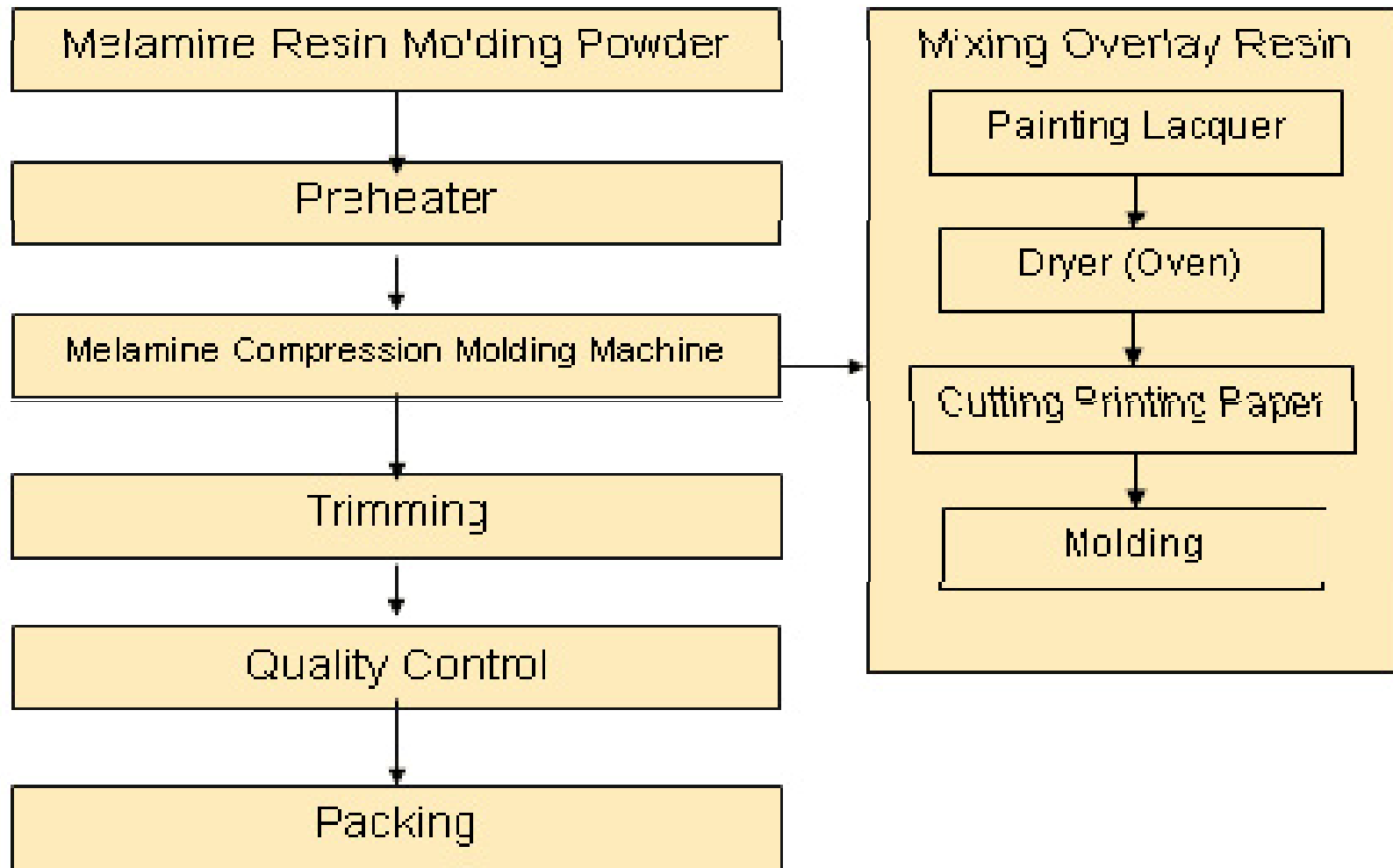

# Melamine Tableware Making Plant Information

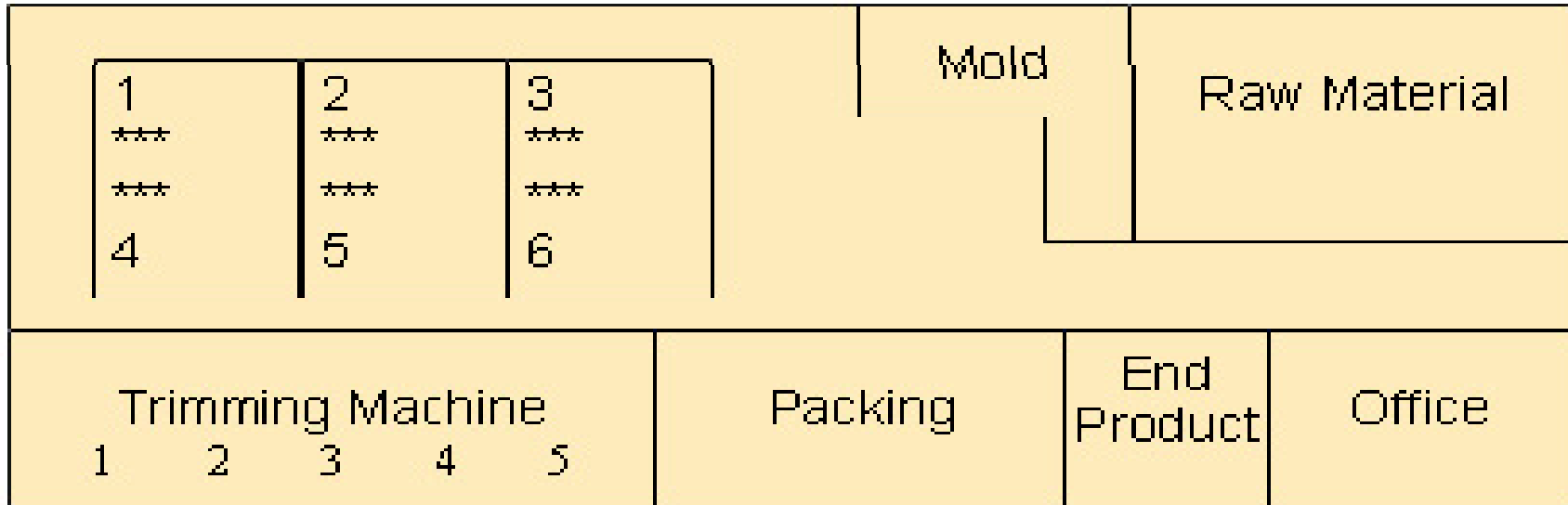

- Floor space – 600 sq m

- Capital Outlay: US\$300-500,000

	<b>Manpower (person)</b>
Plant Manager	1
Production Technician	1
Foreman	2
Operator	10
General Worker	1
<b>Total</b>	<b>15</b>

# Tableware Moulding Machine



***Dense Two Color Melamine  
Tableware Moulding Machine***

## Technical parameters:

Pressure	200 tonnes
Plate size	600 x 600 mm
Cylinder diameter	360 mm
Maximum stroke	400 mm
Motor	10 HP
Heater capacity	10.8 kW
Oil reservoir capacity	120 gallons
Machine size	2530 x 1500 x 2150 mm
Kind	Twin-Screw
Processing	Extruder
Type	Plastic Product Hydraulic Press
Company	Fujian Hongan Machinery Co. Limited

# Adhesives



# Adhesives

- Adhesives are a range of high quality glues specifically designed for the trade to bond a wide array of decorative laminates, melamine board, wood and wood-based panel products.
- Each adhesive has been developed and selected to suit most applications required by cabinet makers, joiners, furniture manufacturers, post-formers and builders.
- Melamine Adhesives are among the many adhesive in use. Due to the availability of urea formaldehyde, Trinidad and Tobago is perfectly suitable for small plant adhesive manufacturing.

# Market Data

- There has been an increase in demand for multiple speciality high performance and nano-formula adhesives. This is as a result of requirements of the automobile, aircraft, construction and other industries. As such, overall global production for specialty adhesives at present appears to be highly favourable.
- Overall global market demand is excellent with increasing demand from this Region, the US, South and Central America, Africa and EU markets.
- Forecast projected growth for the next 10 years is expected to be about 5% per annum.
- Due to the hundreds of different formulae of adhesives, current retail prices for adhesives could vary from regular store pricing to NASA and other space travel speciality needs. The future is promising because of the many new innovative extreme performance adhesives, creative internet or e-marketing, innovations in industry and the current global economies' desire to cut costs.
- The historical demand for adhesives has increased by 5% annually over the last ten years.
- Specific target markets are worldwide.
- Major potential barriers to accessing these markets are: product shelf life, trade restrictions, MSDS restrictions, obtaining contract manufacturing agreements, stringent quality control and potential environmental impact concerns.
- Major Manufacturers include:
  - Astra Chemtech Private Limited (India)
  - Wilsonart (USA)
  - 3M (USA)
  - Conpro Chemicals Private Limited (India)
  - IPS (USA)
- Major sources for supplying turnkey operations and equipment are from China, Taiwan, US, India and EU.
- Manufacturing adhesives are a relatively competitive business. There are several hundred small and a few mega manufacturers and suppliers. Manufacturers' technologies for specific products are proprietary.

# Adhesives

Item	Estimated Requirements *
Floor Space	1,000 – 3,000 sq m
CapEx	US\$800,000 – 4,000,000
Working Capital	US\$200,000 – 1,000,000
Capacity range	3,000 gallons per week
Manpower requirement	40 – 60
Utility Requirements	400 kW electricity 40 tpd water
Potential Markets	T&T, SA, CA, Africa, US, Middle East
Other Input Materials	Urea formaldehyde

\* depending on plant size and level of automation



# Adhesives Processing Equipment



***Resin Production Equipment***

## Technical parameters:

Packing	Packaged as Per Customer Request
Model No.	YD-FS-005
Origin	China
Min. Order	1 Unit
Transportation Type	as per Customer Request Complete Set of Chemical Equipment
Product Type	Alkyd Resin, Acrylic Resin, Epoxy
Machine Material	Stainless Steel/Carbon Steel
Application	Alkyd Resin, Phenolic Resin, Hotmelt Glue, melamine resin
Function	Heat, React, Dilute

# Coatings



# Coatings

- Melamine-formaldehyde resins are used in specially formulated resin systems to produce highly durable coatings.
- Typical melamine-modified coatings applications include:
  - Vehicle body panels
  - Household appliances
  - Drink cans
  - Coils of metal sheeting
- Benefits of melamine-modified coatings include:
  - Good color retention
  - Wear resistance
  - Scratch resistance
  - Glossy finish

# Market Data

- An increased demand for multiple speciality and fire retardant high performance and nano formula coatings in the automobile, aircraft, construction, household and other industrial uses has resulted in an increase in overall global production for speciality coatings.
- Overall global market demand is good with increasing demand expected from this Region, the US, South and Central America, Africa and EU markets.
- Forecast projected growth for the next 10 years is about 5% per annum.
- Market drivers in the future will include creative use of the internet or e-marketing, innovations in the industry and good economics. Due to the many different formulas for speciality coatings, current retail prices for coatings could vary from the average corner store pricing to that used by NASA for space travel requirements.
- The historical demand for coatings has increased considerably over the last ten years.
- Specific target markets are worldwide with emphasis on the Region, South and Central America, Africa and the US markets.
- Major potential barriers to accessing these markets are: product shelf life, trade restrictions, MSDS restrictions, obtaining contract manufacturing agreements, quality control and potential environmental impact concerns.
- Manufacturing coatings, with multinational dominance in the industry, is a relatively competitive business. There are several hundred small and some mega manufacturers and suppliers. Manufacturers' technologies for the product are proprietary.
- Major manufacturers include:
  - Akzo Nobel (Netherlands)
  - Sherwin-Williams (USA)
  - PPG (USA)
  - Materis (France)
  - Benjamin Moore (USA)
- Major sources for supplying turnkey operations and equipment are from China, Taiwan, US, India and EU.

# Coatings

Item	Estimated Requirements “
Floor Space	1,000 sq m
CapEx	US\$300,000 – 1,500,000
Working Capital	US\$75,000 – 375,000
Capacity range	4,000 gallons per week
Manpower requirement	30 – 50
Utility Requirements	300 kW electricity 40 tpd water
Potential Markets	T&T, SA, CA, Africa
Other Input Materials	formaldehyde

\* depending on plant size and level of automation

# Coatings



Interior Wall Paint Mixing Machine

# Flow Diagram of Melamine Coating Manufacturing Plant

Raw materials more than required are added for the First mixing

Raw materials less than required are added for the second mixing

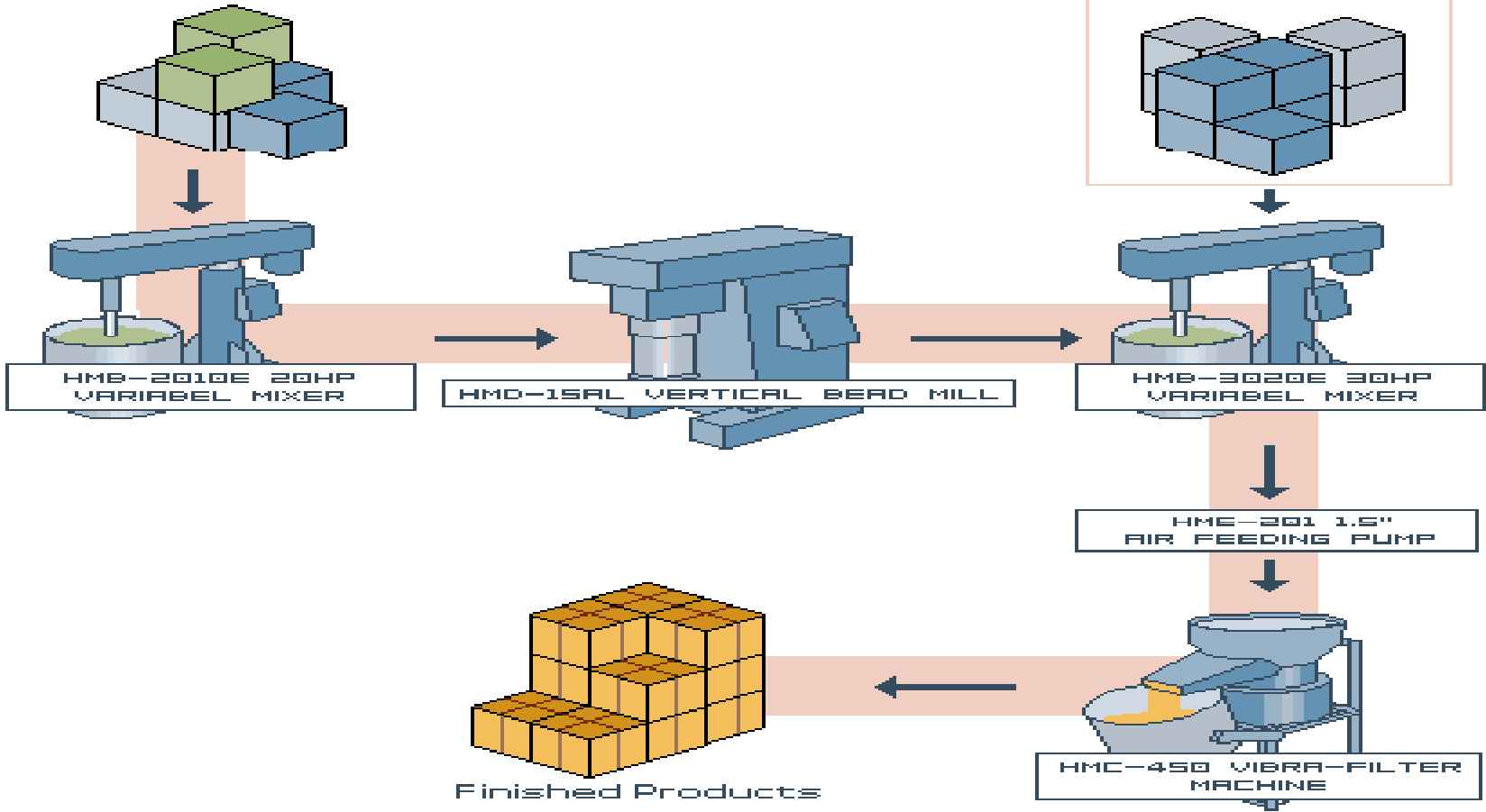

# Typical Plant Requirements

Paint Type	Equipment	Quantity	Electricity
Ready Mixed Paint, Red Iron Oxide Anti- Corrosion Primer, Lacquer Paint, Enamel, Car Baking Enamel, Polyurethane Paint.	1. HMB-2010E 20HP Mixer.	3	320HP (240 kW)
	2. HMB-3020E 30HP Mixer.	3	
	3. HMD-15AL Vertical Type Bead Mill.	3	
	4. HMD-30AL Vertical Type Bead Mill.	3	
	5. HMC-405 Vibra-Filter Machine.	6	
	6. HME-101 1" Air Feeding Pump.	6	
	7. HMK-300 (300 litre) Mixing Tank.	8	
	8. HMK-500 (500 litre) Mixing Tank.-	8	
	9. HMK-800 (800 litre) Mixing Tank.	8	

Position	Staffing requirement
Plant Manager	1
Chemical Engineer	1
Formula Technician	6
Product Testing Operator	2
Assistant Worker	10
Packaging Worker	10

# Laminates

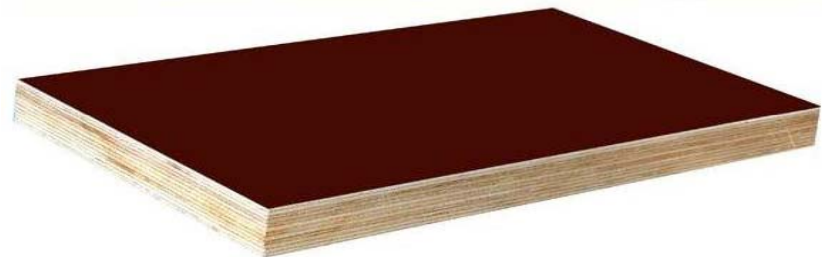

# Laminates

- Melamine laminate is a protective, heat- and scratch-resistant covering for furniture and other surfaces.
- Melamine laminate is a tough material that is resistant to heat, moisture and chemicals. It does not scratch easily, and it is a flame retardant.
- Melamine laminate also has antibacterial properties, making it a hygienic material for use in the kitchen.

# Market Data

- Trinidad and Tobago is not a timber rich country. With new demand for low cost furnishings and do it yourself input, the manufacturing of melamine sheets for adhesive application on wood may be the best bet for local manufacturing. The laminated board business is still flourishing worldwide, especially in the US and in timber rich Brazil and Southern Africa.
- Overall global market demand is positive with increasing demand expected from this Region, the US, South and Central America, Africa and EU markets.
- Forecast projected growth for the next 10 years is approximately 1.5% per annum.
- The future market will be driven by creative internet or e-marketing, innovations in the industry and economics. Local experience and the nurtured creative ingenuity could be used to create local unique laminate patterns. However, it should be noted that laminate production is a very competitive business.
- The historical demand for laminates has been relatively flat over the last ten years.
- Specific target markets are worldwide with emphasis on the Region, South and Central America, Africa and the US markets.
- There are no major potential barriers to accessing these markets.
- Manufacturing laminates with multinational dominance in the industry will be very competitive. Most manufacturers' technologies for the product are proprietary.
- Major manufacturers include:
  - Golden Laminates Ltd, India Ltd. (India)
  - Anpco Products (USA)
  - [Fuzhou Yilida Wood Industry Co., Ltd.](#) (China)
  - [Xiamen Nan Hua Wen Co., Ltd.](#) (China)
  - [Changzhou Chaomei Wood Co., Ltd.](#) (China)
- Major sources for supplying turnkey operations and equipment are from China, Taiwan, US, India and EU.

# Laminates

Item	Estimated Requirements*
Floor Space	2,000 sq m
CapEx	US\$300,000 – 1,500,000
Working Capital	US\$75,000 – 375,000
Capacity range	3,000 - 10,000 sq m per day
Manpower requirement	40 – 100
Utility Requirements	700 kW electricity 60 tpd water
Potential Markets	T&T, SA, CA, Africa, US, Middle East
Other Input Materials	Urea formaldehyde

\* depending on plant size and level of automation

# Laminates



***Paper Laminating Machine***

## Technical parameters

Mode Specification	0320 x 1350 mm
Minimum Board Length	600 mm
Board Width	1220 mm
Board Thickness	2 – 30 mm
Feeding Speed	1 – 18 m per min
Motivity Power	15kW
Heating Power	36 kW
Paper Width	1280 mm
Overall Dimensions	2100 x 235 x 4200 mm
Machine Weight	10 tonnes

# Plasticizers



# Plasticizers

- Plasticizers are additives that increase the plasticity or fluidity of the material to which they are added. These can include plastics, cement, concrete, wallboard, and clay.
- Plasticizers for concrete increase the workability of the wet mix, or reduce the water required to achieve the desired workability, and are usually not intended to affect the properties of the final product after it hardens.
- Plasticizers for wallboard increase fluidity of the mix, allowing lower use of water and thus reducing energy to dry the board.
- Plasticizers for plastics soften the final product increasing its flexibility.

# Market Data

- While newly engineered plasticizers are frequently emerging in almost every industry, many plasticizer users usually stick to traditional formulas. For countries, like Trinidad and Tobago that are rich in petrochemical feedstock, competitively priced energy, intellectual and cultural capital, these assets can be used to persuade traditional bulk buyers to contract traditional plasticizer blends from a local manufacturer.
- Due to the overall global market downturn, the use of concrete plasticizers has declined to a great extent as a result of the decrease in construction activity throughout the world.
- Forecast for projected growth for the next 15 years appears to be somewhat flat. Developing economies like India and China are major producers of plasticizers. Due to the low labour costs in these countries, inexpensive traditional plasticizers are being exported from those markets.
- The future market would be driven by product quality, adequate delivery mechanisms, creative internet or e-marketing, innovations in the industry and world economics.
- The historical demand for concrete plasticizers has dropped considerably over the last ten years due to a decline in construction activities.
- Specific target markets are worldwide with emphasis on the Region, South and Central America, Africa and the US and EU markets.
- Major potential barriers to accessing these markets are: product shelf life, trade restrictions, MSDS restrictions, obtaining contract manufacturing agreements and quality control.
- Manufacturing plasticizers, with Asian dominance in the industry makes it a very competitive business. There are several hundred small and some mega manufacturers and suppliers. Manufacturers' technologies for specific products are proprietary.
- Major manufacturers include:
  - [Beijing Hengan Admixture Co., Ltd.](#) (China)
  - [Hunan Pioneer Building Material Co., Ltd.](#) (China)
  - [Shandong Tongsheng Building Materials Co., Ltd.](#) (China)
  - [Shandong Tongsheng Building Materials Co., Ltd.](#) (China)
  - [Suzhou Sunbo Chemical Building Materials Co., Ltd.](#) (China)
- Major sources for supplying turnkey operations and equipment are from China, Taiwan, US, India and EU.

# Plasticizers

Item	Estimated Requirements *
Floor Space	1,000 sq m
CapEx	US\$300,000 – 1,500,000
Working Capital	US\$60,000 – 300,000
Capacity range	2,000 gallons per day
Manpower requirement	30 – 50
Utility Requirements	250 kW electricity 20 tpd water
Potential Markets	T&T, SA, CA, Africa, US, Middle East, Europe
Other Input Materials	Sulphur Compounds

\* depending on plant size and level of automation

# Conclusion

- Successful marketing campaign for the Melamine Profiles at the Caribbean Investment Forum (CIF) and Trade and Industry Convention (TIC).
- Strong expressions of interest from several local and foreign entities.
- NEC is in the process of developing business plans for the opportunities identified in the profiles.
- NEC has engaged the assistance of the Business Development Company (BDC) and other agencies to identify and locate markets for the products from the projects.
- Identifying and contacting equipment manufacturers and technology providers with a view of visiting their facilities to assess the requirements for establishing plants in Trinidad.

# Thank You

